

# M1 ECU

---

- Hardware



**TECH NOTE**

**MoTeC**

Printed documents are not controlled

While every effort has been taken to ensure correctness, MoTeC, its employees, contractors and authorised representatives and agents take no responsibility, make no express or implied guarantees, representations or warranties to any third party in relation to consequences arising from any inaccuracies or omissions in this document.

This is a proprietary document and the property of MoTeC Pty. Ltd. No part of this publication may be reproduced in any retrieval system, or transmitted in any form or by any means, whether electronic, graphic, mechanical, photocopy, recorded or otherwise, without the prior express written permission of MoTeC.

MoTeC reserves the right to make changes to this document without notice.

Copyright 2013

All rights reserved.

# Table of Contents

Copyright .....	2
<b>Hardware Variants</b> .....	5
<b>Model Comparison Tables</b> .....	6
<b>M1 Inputs</b> .....	7
Analogue Voltage .....	7
Analogue Temperature .....	7
Lambda Narrow .....	8
Knock .....	8
Internal Supply Voltages .....	8
Internal 3 Axis G Sensor .....	8
Internal Temperature .....	9
Fixed Digital .....	9
Universal Digital .....	9
<b>M1 Outputs</b> .....	10
Low Side Output .....	10
Half Bridge Output .....	11
Full Bridge Output .....	11
Low Side Injector Output .....	12
Peak Hold Injector Output .....	12
Low Side Ignition .....	13
Direct Injector Inductive .....	13
Direct Injector Piezo .....	14
Supply Voltage Outputs .....	14
<b>M1 Communications</b> .....	15
<b>Pinouts</b> .....	16
M130 Pinout .....	16
M142 Pinout .....	19
M150 Pinout .....	24
M170 Pinout .....	29
M182 Pinout .....	32
M190 Pinout .....	37
<b>Dimensions and Mounting</b> .....	42
M130 .....	42
M142 / M150 .....	43
M170 .....	44
M182 / M190 .....	45



## Hardware Variants

Feature	M130	M141 / M142	M150	M170	M181 / M182	M190
Logged Memory	128 MB	128 MB	256 MB	256 MB	256 MB	256 MB
Physical						
Case	Small	Large	Large	Small	Large	Large
Connector	Plastic	Plastic	Plastic	Autosport	Autosport	Autosport
Marine Option	Yes	No	No	No	No	No

Current M1 hardware falls into two connector variants, two case variants, and two injector output variants:

### Connector:

- Plastic: AMP 26 and 34 way sureseal connectors with alternate keying as required.
- Autosport: MIL-SPEC 26, 55 and 66 way connectors.

### Case:

- Small: 107 x 127 x 39mm with two plastic connectors or one Autosport 66 way connector.
- Large: 162 x 127 x 39mm with four plastic connectors or three Autosport connectors (2 x 55 with unique keying and 1 x 26).

### Injector Outputs:

- Port injection: a combination of Low Side and Peak Hold Injector outputs.
- Direct injection: hardware specific variants for inductive and piezo injectors.

## Model Comparison Tables

### Inputs

Feature	M130	M141 / M142	M150	M170	M181 / M182	M190
Analogue Voltage	8	17	17	8	17	17
Analogue Temperature	4	6	6	4	6	6
Knock	2	4	4	2	4	4
Lambda Narrow	-	2	2	-	2	2
Fixed Digital	-	4	4	-	4	4
Universal Digital	7	12	12	8	12	12

### Outputs

Feature	M130	M141 / M142	M150	M170	M181 / M182	M190
Low Side Output	-	-	-	-	-	6
Half Bridge Output	6	10	10	6	10	10
Low Side Injector	2	6	6	2	6	12
Peak Hold Injector	8	-	12	8	-	12
Direct Injector	-	8	-	-	12	-
Low Side Ignition	8	8	12	8	12	12

### Communications and Supplies

Feature	M130	M141 / M142	M150	M170	M181 / M182	M190
CAN 2.0B	1	3	3	1	3	3
LIN	-	1	1	-	1	1
RS232	-	1	1	-	1	1
Ethernet 10/100	1	1	1	1	1	1
+5V Output	2	3	3	2	3	3
+6V3 Output	1	1	1	1	1	1
Continuous Battery Input	1	1	1	1	1	1

## M1 Inputs

### Analogue Voltage

- External, calibrated, inputs which measure absolute voltage.
- Typically used with ratiometric 3 wire sensors such as throttle position, pressure, etc.
- Power supply for ratiometric sensors can be specified for improved accuracy.

#### Representative circuit

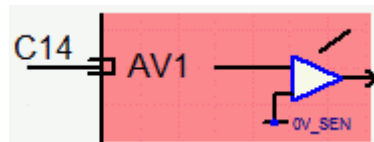

- 12 bit analogue to digital converters with 0V - 6.098V input range and a precision internal reference.
- Input impedance 100K.
- 230Hz bandwidth.
- Transient input +/-200V.
- Continuous no damage input voltage range -30 to +35V.
- Either 8 or 17 AV pins per device - hardware dependant.
- Supports absolute and ratiometric measurement.

### Analogue Temperature

- External, calibrated, inputs which measure absolute voltage.
- Typically used with variable resistor 2 wire sensors such as engine temperature, air temperature, etc.

#### Representative circuit

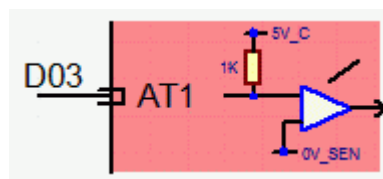

- 12 bit analogue to digital converters with 0V - 6.098V input range and a precision internal reference.
- Input impedance 100K, 1K pullup to 5V.
- 230Hz bandwidth.
- Transient input +/-200V.
- Continuous no damage input voltage range -30 to +35V.
- Either 4 or 6 AT pins per device - hardware dependant.

## Lambda Narrow

- External, calibrated, inputs which measure absolute voltage.
- Typically for direct connection to narrow band lambda sensors.

### Representative circuit

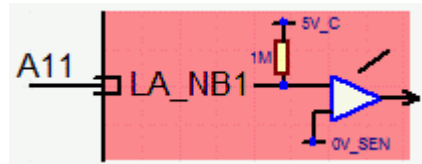

- 12 bit analogue to digital converters with 0V - 6.098V input range and a precision internal reference.
- Can also be used for voltage measurements.
- Input impedance 100K.
- Transient input +/-200V.
- Continuous no damage input voltage range -30 to +35V.
- Either 0 or 2 Narrow Lambda pins per device - hardware dependant.

## Knock

- Digital Signal Processed knock detection.

### Representative circuit

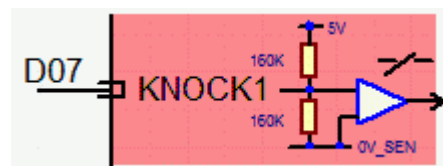

- 12 bit analogue to digital converters with -0.562 to 5.562V input range.
- Can also be used as high speed AV inputs.
- Input impedance equivalent to 98k with 2.5V offset.
- 50KHz bandwidth.
- Transient input +/-200V.
- Continuous no damage input voltage range -30 to +35V.
- Either 2 or 4 Analogue Knock pins per device - hardware dependant.

## Internal Supply Voltages

All internal supply rails are monitored and operate in a similar fashion to Analogue Voltage inputs, where fault tolerances and default values may be specified. In addition the system supply (Battery Positive) is monitored.

## Internal 3 Axis G Sensor

- Broad band inputs.
- Primarily for use in vibration analysis of the M1 ECU itself.
- External G sensors are recommended for vehicle dynamics functions.



## Internal Temperature

This sensor is intended for ECU temperature monitoring and may be logged at a suitable rate for overall ECU health status.

## Fixed Digital

- Internal pull up (not switchable) – 4k7 to +3V3 supply.

### Representative circuit

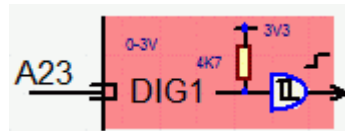

- Logic level – 2V threshold.
- 0-20KHz operation.
- Either 0, 4 or 7 Fixed DIG pins per device - hardware dependant.

## Universal Digital

- Input waveform capture (10bit) range -10.668 to 11.472V ( 21.64mV per step)
- Programmable trigger levels +/-10V
- Programmable hysteresis levels 0.1 to 6.0V
- Programmable digital filtering
- Suitable for hall/optical and magnetic sensors

### Representative circuit

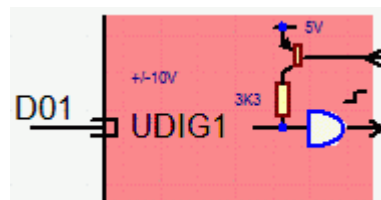

- Switchable pullup resistor – 3k3 via diode to +5V supply.
- Can be used for REF/SYNC, CAM position, wheel speed, turbo speed etc. Can also be used as redundant REF/SYNC.
- Diagnostics: Threshold Noise, Hysteresis Noise, Rejected Pulse and Small Pulse.
- Peak voltage 200V
- RMS voltage 70V
- Either 7, 8 or 12 UDIG pins per device - hardware dependant.

## M1 Outputs

### Low Side Output

- Mnemonic within Build and Tune is OUT\_LS.
- 2 Amp open collector outputs (switch to BAT\_NEG).

Representative circuit

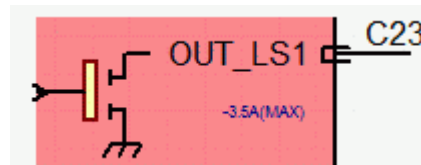

- No internal recirculation circuitry. Cam solenoids require external recirculation diode.
- Pin voltage monitored by 12 bit A/D converter (per output).
- 24bit timers 0.25 usec resolution.
- Max voltage 40V.
- Max current 3.5 Amps minimum.
- RMS current 2 Amps.
- Maximum output frequency in PWM modes: low side drive 20KHz.
- Either 0 or 6 Low Side Output pins per device - hardware dependant.
- Suitable for pulsed outputs such as boost control valves which require rapid current decay when the output turns off.
- Suitable for permanently powered loads.

## Half Bridge Output

➤ *Parasitic power feed is possible via this output. Ensure that permanently powered loads (such as relays, solenoids, etc.) are not connected to these outputs.*

- Mnemonic within Build and Tune is OUT\_HB.
- 12 Amp low side driver and 9 Amp high side driver.

**Representative circuit**

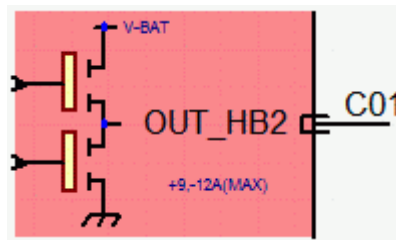

- Recirculation via internal high side FET. Cam solenoids may be wired without external recirculation diode.
- Both high and low side drivers can be PWM.
- Pin voltage monitored by 12 bit A/D converter (per output) .
- 24bit timers 0.25usec resolution.
- Suitable for servo throttle (Drive by Wire) (2 outputs required).
- Suitable for general purpose DC servo drive.
- Max current LS 12 Amps minimum.
- Max current HS 9 Amps minimum.
- RMS current 4 Amps.
- Maximum output frequency in PWM modes: low side drive 20KHz, high side drive 1KHz.
- Either 6 or 10 Half Bridge Output pins per device - hardware dependant.
- Loads must be connected to either ECU BAT\_POS or ECU BAT\_NEG in a full bridge configuration.

## Full Bridge Output

- Composite output pairs comprised of Half Bridge Output pins.
- Mix of Half Bridge and Full Bridge outputs possible .
- Recirculation via internal high side FETs.
- Either 3 or 5 Full Bridge Outputs per device - hardware dependant.

## Low Side Injector Output

- Mnemonic within Build and Tune is INJ\_LS
- 2 Amp open collector saturated drive (switch to BAT\_NEG) suitable for high impedance injectors (> 12 Ohms).

Representative circuit

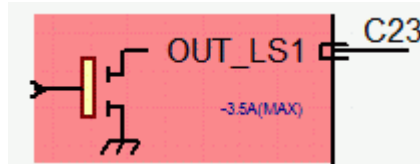

- No internal recirculation circuitry. Cam solenoids require external recirculation diode.
- Can also be used as PWM aux output.
- 24bit timers 0.1usec resolution.
- Max voltage 60V.
- Max current 3.5 Amps minimum.
- RMS current 2 Amps.
- Either 2, 6 or 12 Low Side Injector pins per device - hardware dependant.
- Suitable for permanently powered loads.

## Peak Hold Injector Output

➤ *Peak Hold Injector supplies should be common with BAT\_POS supplies, terminated as close as possible to the M1 supply pins.*

- Mnemonic within Build and Tune is INJ\_PH.
- Open collector output via current sense resistor, switchable recirculation.

Representative circuit

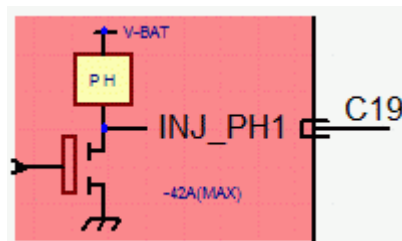

- Programmable peak current (8 bit per output) up to 8 Amps.
- Programmable hold current (8 bit per output) up to 4 Amps.
- Optional peak hold and HI-Z mode.
- Diagnostics for Short, Open and High Impedance.
- Pin voltage monitored by 12 bit A/D converter (per output).
- 24bit timers 0.1usec resolution.
- Flyback clamping voltage 40V.
- RMS current 2 Amps.
- Either 8 or 12 Peak Hold Injector pins per device - hardware dependant.

## Low Side Ignition

- Mnemonic within Build and Tune is IGN\_LS .
- 2 Amp open collector outputs (switch to BAT\_NEG).
- 0-40mA programmable current source (8bit).
- All IGN\_LS outputs are driven from individual current sources. All current sources are enabled together.

**Representative circuit**

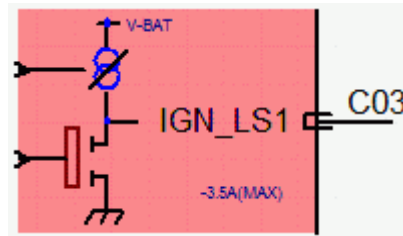

- No internal recirculation circuitry. Cam solenoids require external recirculation diode.
- Pin voltage monitored by 12 bit A/D converter (per output).
- Can also be used as PWM aux output.
- 24bit timers 0.1usec resolution.
- Max voltage 40V.
- Max current 3.5 Amps minimum .
- RMS current 2 Amps.
- Either 8 or 12 Low Side Ignition pins per device - hardware dependant.

## Direct Injector Inductive

- Mnemonic within Build and Tune is INJ\_D
- Programmable peak current (8 bit per output) – up to 12 Amp.
- Programmable hold current (8 bit per output).
- Capable of peak hold function.
- Diagnostics for Short, Open and High Impedance.
- Pin voltage monitored by 12 bit A/D converter (per output).
- 24bit timers 0.1usec resolution.
- Supply voltage programmable from 20 to 90V.
- RMS current 3 Amps.
- Each driver uses 2 pins - high side and low side.
- Either 4, 8 or 12 Direct Injector Drivers per device - hardware dependant.

## Direct Injector Piezo

- Mnemonic within Build and Tune is INJ\_D
- Constant current charge and discharge mode for piezo injectors.
- Programmable charge/discharge current 0-15Amps.
- Diagnostics for Short, Open and High Impedance.
- Pin voltage monitored by 12 bit A/D converter (per output).
- 24bit timers 0.1usec resolution.
- Supply voltage programmable from 20 to 180V.
- RMS current 3 Amps.
- Each driver uses 2 pins - high side and low side.
- Either 4, 8 or 12 Direct Injector Drivers per device - hardware dependant.

## Supply Voltage Outputs

- Supply and Zero volt outputs for 5V and 6V3 Sensor supplies.
- Zero volt outputs are FET driven earths:
  - Not suitable for scope probes or other earths.
  - Do not provide an earth path when the ECU is not powered.

Care should be taken in wiring loom design to ensure that no current paths are routed to Sensor Zero Volt pins.

## M1 Communications

---

- Ethernet. 1 10/100 Ethernet port on all devices.
- CAN.
  - Up to 3 CAN busses , with a minimum of 1 on all devices.
  - Definable CAN speeds, timeouts, transmit, and receive messaging.
  - CAN messaging is implemented in the CanComms libraries which are incorporated into scripts by the application developer.
- LIN. 1 LIN (bidirectional) on some devices.
- RS232. 1 RS232 Txd and RS232 Rxd on some devices.

## Pinouts

### M130 Pinout

#### M130 Connector A — 34 way

Mating Connector A: Tyco Superseal 34 Position Keying 1 – MoTeC #65044

Pin Number	Designation	Full Name	OE Pin	Function	Description
A01	OUT_HB2	Half Bridge Output 2			
A02	SEN_5V0_A	Sensor 5.0V A			
A03	IGN_LS1	Low Side Ignition 1			
A04	IGN_LS2	Low Side Ignition 2			
A05	IGN_LS3	Low Side Ignition 3			
A06	IGN_LS4	Low Side Ignition 4			
A07	IGN_LS5	Low Side Ignition 5			
A08	IGN_LS6	Low Side Ignition 6			
A09	SEN_5V0_B	Sensor 5.0V B			
A10	BAT_NEG1	Battery Negative			
A11	BAT_NEG2	Battery Negative			
A12	IGN_LS7	Low Side Ignition 7			
A13	IGN_LS8	Low Side Ignition 8			
A14	AV1	Analogue Voltage Input 1			
A15	AV2	Analogue Voltage Input 2			
A16	AV3	Analogue Voltage Input 3			
A17	AV4	Analogue Voltage Input 4			
A18	OUT_HB1	Half Bridge Output 1			
A19	INJ_PH1	Peak Hold Injector 1			
A20	INJ_PH2	Peak Hold Injector 2			
A21	INJ_PH3	Peak Hold Injector 3			
A22	INJ_PH4	Peak Hold Injector 4			
A23	INJ_LS1	Low Side Injector 1			
A24	INJ_LS2	Low Side Injector 2			
A25	AV5	Analogue Voltage Input 5			
A26	BAT_POS	Battery Positive			
A27	INJ_PH5	Peak Hold Injector 5			



Pin Number	Designation	Full Name	OE Pin	Function	Description
A28	INJ_PH6	Peak Hold Injector 6			
A29	INJ_PH7	Peak Hold Injector 7			
A30	INJ_PH8	Peak Hold Injector 8			
A31	OUT_HB3	Half Bridge Output 3			
A32	OUT_HB4	Half Bridge Output 4			
A33	OUT_HB5	Half Bridge Output 5			
A34	OUT_HB6	Half Bridge Output 6			

### M130 Connector B — 26 way

Mating Connector B: Tyco Superseal 26 Position Keying 1 – MoTeC #65045

Pin Number	Designation	Full Name	OE Pin	Function	Description
B01	UDIG1	Universal Digital Input 1			
B02	UDIG2	Universal Digital Input 2			
B03	AT1	Analogue Temperature Input 1		1k Pull up to SEN_5V_A	
B04	AT2	Analogue Temperature Input 2		1k Pull up to SEN_5V_B	
B05	AT3	Analogue Temperature Input 3		1k Pull up to SEN_5V_A	
B06	AT4	Analogue Temperature Input 4		1k Pull up to SEN_5V_B	
B07	KNOCK1	Knock Input 1			
B08	UDIG3	Universal Digital Input 3			
B09	UDIG4	Universal Digital Input 4			
B10	UDIG5	Universal Digital Input 5			
B11	UDIG6	Universal Digital Input 6			
B12	BAT_BAK	Battery Backup			
B13	KNOCK2	Knock Input 2			
B14	UDIG7	Universal Digital Input 7			
B15	SEN_0V_A	Sensor 0V A			
B16	SEN_0V_B	Sensor 0V B			
B17	CAN_HI	CAN Bus 1 High			
B18	CAN_LO	CAN Bus 1 Low			
B19	SEN_6V3	Sensor 6.3V			
B20	AV6	Analogue Voltage Input 6			
B21	AV7	Analogue Voltage Input 7			
B22	AV8	Analogue Voltage Input 8			

Pin Number	Designation	Full Name	OE Pin	Function	Description
B23	ETH_TX+	Ethernet Transmit+	Ethernet Green/White		
B24	ETH_TX-	Ethernet Transmit-	Ethernet Green		
B25	ETH_RX+	Ethernet Receive+	Ethernet Orange/White		
B26	ETH_RX-	Ethernet Receive-	Ethernet Orange		

## M142 Pinout

### M142 Connector A - 34 Way

Mating Connector A: Tyco Superseal 34 Position Keying 2 – MoTeC #65067

Pin Number	Designation	Full Name	OE Pin	Function	Description
A01	AT5	Analogue Temperature Input 5		1k Pull up to SEN_5V_C	
A02	AT6	Analogue Temperature Input 6		1k Pull up to SEN_5V_C	
A03	AV15	Analogue Voltage Input 15			
A04	AV16	Analogue Voltage Input 16			
A05	AV17	Analogue Voltage Input 17			
A06	INJ_D1A_NEG	Direct Injector 1A -			
A07	INJ_D1A_POS	Direct Injector 1A +			
A08	INJ_D1B_POS	Direct Injector 1B +			
A09	INJ_D1B_NEG	Direct Injector 1B -			
A10	SEN_5V0_C1	Sensor 5.0V C			
A11	LA_NB1	Lambda Narrow Input 1			
A12	LA_NB2	Lambda Narrow Input 2			
A13	KNOCK3	Knock Input 3			
A14	KNOCK4	Knock Input 4			
A15	DIG2	Digital Input 2			
A16	DIG3	Digital Input 3			
A17	DIG4	Digital Input 4			
A18	SEN_5V0_C2	Sensor 5.0V C			
A19	SEN_5V0_B2	Sensor 5.0V B			
A20	LIN	LIN Bus			
A21	RS232_RX	RS232 Receive			
A22	RS232_TX	RS232 Transmit			
A23	DIG1	Digital Input 1			
A24	BAT_NEG3	Battery Negative			
A25	BAT_NEG4	Battery Negative			
A26	SEN_0V_C1	Sensor 0V C			
A27	SEN_0V_C2	Sensor 0V C			
A28	CAN3_HI	CAN Bus 3 High			
A29	CAN3_LO	CAN Bus 3 Low			
A30	CAN2_HI	CAN Bus 2 High			

Pin Number	Designation	Full Name	OE Pin	Function	Description
A31	CAN2_LO	CAN Bus 2 Low			
A32	BAT_NEG5	Battery Negative			
A33	SEN_OV_B1	Sensor 0V B			
A34	SEN_OV_A1	Sensor 0V A			

### M142 Connector B - 26 Way

Mating Connector B: Tyco Superseal 26 Position Keying 3 – MoTeC #65068

Pin Number	Designation	Full Name	OE Pin	Function	Description
B01	OUT_HB9	Half Bridge Output 9			
B02	OUT_HB10	Half Bridge Output 10			
B03	UDIG8	Universal Digital Input 8			
B04	UDIG9	Universal Digital Input 9			
B05	UDIG10	Universal Digital Input 10			
B06	UDIG11	Universal Digital Input 11			
B07	UDIG12	Universal Digital Input 12			
B08	INJ_LS5	Low Side Injector 5			
B09	INJ_LS3	Low Side Injector 3			
B10	AV9	Analogue Voltage Input 9			
B11	AV10	Analogue Voltage Input 10			
B12	AV11	Analogue Voltage Input 11			
B13	BAT_POS	Battery Positive			
B14	INJ_LS6	Low Side Injector 6			
B15	INJ_LS4	Low Side Injector 4			
B16	AV12	Analogue Voltage Input 12			
B17	AV13	Analogue Voltage Input 13			
B18	AV14	Analogue Voltage Input 14			
B19	BAT_POS	Battery Positive			
B20	OUT_HB7	Half Bridge Output 7			
B21	OUT_HB8	Half Bridge Output 8			
B22	INJ_D2A_NEG	Direct Injector 2A -			
B23	INJ_D2A_POS	Direct Injector 2A +			
B24	INJ_D2B_POS	Direct Injector 2B +			
B25	INJ_D2B_NEG	Direct Injector 2B -			

Pin Number	Designation	Full Name	OE Pin	Function	Description
B26	SEN_5V0_A	Sensor 5.0V A			

### M142 Connector C - 34 Way

Mating Connector C: Tyco Superseal 34 Position Keying 1 – MoTeC #65044

Pin Number	Designation	Full Name	OE Pin	Function	Description
C01	OUT_HB2	Half Bridge Output 2			
C02	SEN_5V0_A	Sensor 5.0V A			
C03	IGN_LS1	Low Side Ignition 1			
C04	IGN_LS2	Low Side Ignition 2			
C05	IGN_LS3	Low Side Ignition 3			
C06	IGN_LS4	Low Side Ignition 4			
C07	IGN_LS5	Low Side Ignition 5			
C08	IGN_LS6	Low Side Ignition 6			
C09	SEN_5V0_B	Sensor 5.0V B			
C10	BAT_NEG1	Battery Negative			
C11	BAT_NEG2	Battery Negative			
C12	IGN_LS7	Low Side Ignition 7			
C13	IGN_LS8	Low Side Ignition 8			
C14	AV1	Analogue Voltage Input 1			
C15	AV2	Analogue Voltage Input 2			
C16	AV3	Analogue Voltage Input 3			
C17	AV4	Analogue Voltage Input 4			
C18	OUT_HB1	Half Bridge Output 1			
C19	INJ_D3A_POS	Direct Injector 3A +			
C20	INJ_D3B_POS	Direct Injector 3B +			
C21	INJ_D4A_POS	Direct Injector 4A +			
C22	INJ_D4B_POS	Direct Injector 4B +			
C23	INJ_LS1	Low Side Injector 1			
C24	INJ_LS2	Low Side Injector 2			
C25	AV5	Analogue Voltage Input 5			
C26	BAT_POS	Battery Positive			
C27	INJ_D3A_NEG	Direct Injector 3A -			
C28	INJ_D3B_NEG	Direct Injector 3B -			

Pin Number	Designation	Full Name	OE Pin	Function	Description
C29	INJ_D4A_NEG	Direct Injector 4A -			
C30	INJ_D4B_NEG	Direct Injector 4B -			
C31	OUT_HB3	Half Bridge Output 3			
C32	OUT_HB4	Half Bridge Output 4			
C33	OUT_HB5	Half Bridge Output 5			
C34	OUT_HB6	Half Bridge Output 6			

### M142 Connector D — 26 way

Mating Connector D: Tyco Superseal 26 Position Keying 1 – MoTeC #65045

Pin Number	Designation	Full Name	OE Pin	Function	Description
D01	UDIG1	Universal Digital Input 1			
D02	UDIG2	Universal Digital Input 2			
D03	AT1	Analogue Temperature Input 1		1k Pull up to SEN_5V_A	
D04	AT2	Analogue Temperature Input 2		1k Pull up to SEN_5V_A	
D05	AT3	Analogue Temperature Input 3		1k Pull up to SEN_5V_B	
D06	AT4	Analogue Temperature Input 4		1k Pull up to SEN_5V_B	
D07	KNOCK1	Knock Input 1			
D08	UDIG3	Universal Digital Input 3			
D09	UDIG4	Universal Digital Input 4			
D10	UDIG5	Universal Digital Input 5			
D11	UDIG6	Universal Digital Input 6			
D12	BAT_BAK	Battery Backup			
D13	KNOCK2	Knock Input 2			
D14	UDIG7	Universal Digital Input 7			
D15	SEN_0V_A	Sensor 0V A			
D16	SEN_0V_B	Sensor 0V B			
D17	CAN1_HI	CAN Bus 1 High			
D18	CAN1_LO	CAN Bus 1 Low			
D19	SEN_6V3	Sensor 6.3V			
D20	AV6	Analogue Voltage Input 6			
D21	AV7	Analogue Voltage Input 7			
D22	AV8	Analogue Voltage Input 8			
D23	ETH_TX+	Ethernet Transmit+	Ethernet Green/White		

Pin Number	Designation	Full Name	OE Pin	Function	Description
D24	ETH_TX-	Ethernet Transmit-	Ethernet Green		
D25	ETH_RX+	Ethernet Receive +	Ethernet Orange/White		
D26	ETH_RX-	Ethernet Receive-	Ethernet Orange		

## M150 Pinout

### M150 Connector A - 34 Way

Mating Connector A: Tyco Superseal 34 Position Keying 2 – MoTeC #65067

Pin Number	Designation	Full Name	OE Pin	Function	Description
A01	AT5	Analogue Temperature Input 5		1k Pull up to SEN_5V_C	
A02	AT6	Analogue Temperature Input 6		1k Pull up to SEN_5V_C	
A03	AV15	Analogue Voltage Input 15			
A04	AV16	Analogue Voltage Input 16			
A05	AV17	Analogue Voltage Input 17			
A06	IGN_LS9	Low Side Ignition 9			
A07	IGN_LS10	Low Side Ignition 10			
A08	IGN_LS11	Low Side Ignition 11			
A09	IGN_LS12	Low Side Ignition 12			
A10	SEN_5V0_C1	Sensor 5.0V C			
A11	LA_NB1	Lambda Narrow Input 1			
A12	LA_NB2	Lambda Narrow Input 2			
A13	KNOCK3	Knock Input 3			
A14	KNOCK4	Knock Input 4			
A15	DIG2	Digital Input 2			
A16	DIG3	Digital Input 3			
A17	DIG4	Digital Input 4			
A18	SEN_5V0_C2	Sensor 5.0V C			
A19	SEN_5V0_B2	Sensor 5.0V B			
A20	LIN	LIN Bus			
A21	RS232_RX	RS232 Receive			
A22	RS232_TX	RS232 Transmit			
A23	DIG1	Digital Input 1			
A24	BAT_NEG3	Battery Negative			
A25	BAT_NEG4	Battery Negative			
A26	SEN_0V_C1	Sensor 0V C			
A27	SEN_0V_C2	Sensor 0V C			
A28	CAN3_HI	CAN Bus 3 High			
A29	CAN3_LO	CAN Bus 3 Low			
A30	CAN2_HI	CAN Bus 2 High			



Pin Number	Designation	Full Name	OE Pin	Function	Description
A31	CAN2_LO	CAN Bus 2 Low			
A32	BAT_NEG5	Battery Negative			
A33	SEN_OV_B1	Sensor 0V B			
A34	SEN_OV_A1	Sensor 0V A			

### M150 Connector B - 26 Way

Mating Connector B: Tyco Superseal 26 Position Keying 3 – MoTeC #65068

Pin Number	Designation	Full Name	OE Pin	Function	Description
B01	OUT_HB9	Half Bridge Output 9			
B02	OUT_HB10	Half Bridge Output 10			
B03	UDIG8	Universal Digital Input 8			
B04	UDIG9	Universal Digital Input 9			
B05	UDIG10	Universal Digital Input 10			
B06	UDIG11	Universal Digital Input 11			
B07	UDIG12	Universal Digital Input 12			
B08	INJ_LS5	Low Side Injector 5			
B09	INJ_LS3	Low Side Injector 3			
B10	AV9	Analogue Voltage Input 9			
B11	AV10	Analogue Voltage Input 10			
B12	AV11	Analogue Voltage Input 11			
B13	BAT_POS	Battery Positive			
B14	INJ_LS6	Low Side Injector 6			
B15	INJ_LS4	Low Side Injector 4			
B16	AV12	Analogue Voltage Input 12			
B17	AV13	Analogue Voltage Input 13			
B18	AV14	Analogue Voltage Input 14			
B19	BAT_POS	Battery Positive			
B20	OUT_HB7	Half Bridge Output 7			
B21	OUT_HB8	Half Bridge Output 8			
B22	INJ_PH9	Peak Hold Injector 9			
B23	INJ_PH10	Peak Hold Injector 10			
B24	INJ_PH11	Peak Hold Injector 11			
B25	INJ_PH12	Peak Hold Injector 12			

Pin Number	Designation	Full Name	OE Pin	Function	Description
B26	SEN_5V0_A	Sensor 5.0V A			

### M150 Connector C - 34 Way

Mating Connector C: Tyco Superseal 34 Position Keying 1 – MoTeC #65044

Pin Number	Designation	Full Name	OE Pin	Function	Description
C01	OUT_HB2	Half Bridge Output 2			
C02	SEN_5V0_A	Sensor 5.0V A			
C03	IGN_LS1	Low Side Ignition 1			
C04	IGN_LS2	Low Side Ignition 2			
C05	IGN_LS3	Low Side Ignition 3			
C06	IGN_LS4	Low Side Ignition 4			
C07	IGN_LS5	Low Side Ignition 5			
C08	IGN_LS6	Low Side Ignition 6			
C09	SEN_5V0_B	Sensor 5.0V B			
C10	BAT_NEG1	Battery Negative			
C11	BAT_NEG2	Battery Negative			
C12	IGN_LS7	Low Side Ignition 7			
C13	IGN_LS8	Low Side Ignition 8			
C14	AV1	Analogue Voltage Input 1			
C15	AV2	Analogue Voltage Input 2			
C16	AV3	Analogue Voltage Input 3			
C17	AV4	Analogue Voltage Input 4			
C18	OUT_HB1	Half Bridge Output 1			
C19	INJ_PH1	Peak Hold Injector 1			
C20	INJ_PH2	Peak Hold Injector 2			
C21	INJ_PH3	Peak Hold Injector 3			
C22	INJ_PH4	Peak Hold Injector 4			
C23	INJ_LS1	Low Side Injector 1			
C24	INJ_LS2	Low Side Injector 2			
C25	AV5	Analogue Voltage Input 5			
C26	BAT_POS	Battery Positive			
C27	INJ_PH5	Peak Hold Injector 5			
C28	INJ_PH6	Peak Hold Injector 6			

Pin Number	Designation	Full Name	OE Pin	Function	Description
C29	INJ_PH7	Peak Hold Injector 7			
C30	INJ_PH8	Peak Hold Injector 8			
C31	OUT_HB3	Half Bridge Output 3			
C32	OUT_HB4	Half Bridge Output 4			
C33	OUT_HB5	Half Bridge Output 5			
C34	OUT_HB6	Half Bridge Output 6			

## M150 Connector D — 26 way

Mating Connector D: Tyco Superseal 26 Position Keying 1 – MoTeC #65045

Pin Number	Designation	Full Name	OE Pin	Function	Description
D01	UDIG1	Universal Digital Input 1			
D02	UDIG2	Universal Digital Input 2			
D03	AT1	Analogue Temperature Input 1		1k Pull up to SEN_5V_A	
D04	AT2	Analogue Temperature Input 2		1k Pull up to SEN_5V_A	
D05	AT3	Analogue Temperature Input 3		1k Pull up to SEN_5V_B	
D06	AT4	Analogue Temperature Input 4		1k Pull up to SEN_5V_B	
D07	KNOCK1	Knock Input 1			
D08	UDIG3	Universal Digital Input 3			
D09	UDIG4	Universal Digital Input 4			
D10	UDIG5	Universal Digital Input 5			
D11	UDIG6	Universal Digital Input 6			
D12	BAT_BAK	Battery Backup			
D13	KNOCK2	Knock Input 2			
D14	UDIG7	Universal Digital Input 7			
D15	SEN_0V_A	Sensor 0V A			
D16	SEN_0V_B	Sensor 0V B			
D17	CAN1_HI	CAN Bus 1 High			
D18	CAN1_LO	CAN Bus 1 Low			
D19	SEN_6V3	Sensor 6.3V			
D20	AV6	Analogue Voltage Input 6			
D21	AV7	Analogue Voltage Input 7			
D22	AV8	Analogue Voltage Input 8			
D23	ETH_TX+	Ethernet Transmit+	Ethernet Green/White		

Pin Number	Designation	Full Name	OE Pin	Function	Description
D24	ETH_TX-	Ethernet Transmit-	Ethernet Green		
D25	ETH_RX+	Ethernet Receive +	Ethernet Orange/White		
D26	ETH_RX-	Ethernet Receive-	Ethernet		

## M170 Pinout

### M170 Connector A — 66 way

Mating Connector A: Autosport 66 way Red - (Deutsch) AS6-18-35SN – MoTeC #65035

Pin Number	Designation	Full Name	OE Pin	Function	Description
A01	IGN_LS1	Low Side Ignition 1			
A02	IGN_LS8	Low Side Ignition 8			
A03	IGN_LS7	Low Side Ignition 7			
A04	IGN_LS3	Low Side Ignition 3			
A05	IGN_LS2	Low Side Ignition 2			
A06	AV3	Analogue Voltage Input 3			
A07	AV4	Analogue Voltage Input 4			
A08	OUT_HB2	Half Bridge Output 2			
A09	OUT_HB1	Half Bridge Output 1			
A10	IGN_LS4	Low Side Ignition 4			
A11	SEN_0V_A	Sensor 0V A			
A12	AV5	Analogue Voltage Input 5			
A13	UDIG7	Universal Digital Input 7			
A14	BAT_NEG1	Battery Negative			
A15	BAT_NEG2	Battery Negative			
A16	SEN_5V0_A	Sensor 5.0V A			
A17	IGN_LS5	Low Side Ignition 5			
A18	AV2	Analogue Voltage Input 2			
A19	BAT_NEG3	Battery Negative			
A20	BAT_NEG4	Battery Negative			
A21	BAT_NEG5	Battery Negative			
A22	UDIG8	Universal Digital Input 8			
A23	BAT_POS	Battery Positive			
A24	INJ_PH5	Peak Hold Injector 5			
A25	IGN_LS6	Low Side Ignition 6			
A26	AV1	Analogue Voltage Input 1			
A27	SEN_0V_B	Sensor 0V B			
A28	AT1	Analogue Temperature Input 1		1k Pull up to SEN_5V_A	
A29	KNOCK1	Knock Input 1			
A30	AT3	Analogue Temperature Input 3		1k Pull up to SEN_5V_A	

Pin Number	Designation	Full Name	OE Pin	Function	Description
A31	CAN_LO	CAN Bus 1 Low			
A32	BAT_POS	Battery Positive			
A33	INJ_PH1	Peak Hold Injector 1			
A34	SEN_5V0_B	Sensor 5.0V B			
A35	AV7	Analogue Voltage Input 7			
A36	AV6	Analogue Voltage Input 6			
A37	SEN_6V3	Sensor 6.3V			
A38	AT2	Analogue Temperature Input 2		1k Pull up to SEN_5V_B	
A39	AT4	Analogue Temperature Input 4		1k Pull up to SEN_5V_B	
A40	CAN_HI	CAN Bus 1 High			
A41	BAT_POS	Battery Positive			
A42	INJ_PH6	Peak Hold Injector 6			
A43	INJ_LS1	Low Side Injector 1			
A44	AV8	Analogue Voltage Input 8			
A45	UDIG4	Universal Digital Input 4			
A46	UDIG3	Universal Digital Input 3			
A47	ETH_TX-	Ethernet Transmit-	Ethernet Green		
A48	ETH_TX+	Ethernet Transmit+	Ethernet Green/White		
A49	UDIG1	Universal Digital Input 1			
A50	INJ_PH2	Peak Hold Injector 2			
A51	INJ_LS2	Low Side Injector 2			
A52	UDIG5	Universal Digital Input 5			
A53	UDIG6	Universal Digital Input 6			
A54	BAT_BAK	Battery Backup			
A55	ETH_RX+	Ethernet Receive+	Ethernet Orange/White		
A56	UDIG2	Universal Digital Input 2			
A57	INJ_PH7	Peak Hold Injector 7			
A58	OUT_HB5	Half Bridge Output 5			
A59	OUT_HB3	Half Bridge Output 3			
A60	KNOCK2	Knock Input 2			
A61	ETH_RX-	Ethernet Receive-	Ethernet Orange		
A62	INJ_PH8	Peak Hold Injector 8			

Pin Number	Designation	Full Name	OE Pin	Function	Description
A63	INJ_PH3	Peak Hold Injector 3			
A64	OUT_HB6	Half Bridge Output 6			
A65	OUT_HB4	Half Bridge Output 4			
A66	INJ_PH4	Peak Hold Injector 4			

## M182 Pinout

### M182 Connector A — 55 way

Mating Connector A: Autosport 55 way Green - (Deutsch) AS6-16-35SD – MoTeC #65032

Pin Number	Designation	Full Name	OE Pin	Function	Description
A01	INJ_D1A_POS	Direct Injector 1A +			
A02	INJ_D2A_POS	Direct Injector 2A +			
A03	INJ_D2B_POS	Direct Injector 2B +			
A04	INJ_D4A_POS	Direct Injector 4A +			
A05	INJ_D1B_POS	Direct Injector 1B +			
A06	LA_NB2	Lambda Narrow Input 2			
A07	LA_NB1	Lambda Narrow Input 1			
A08	SEN_5V0_C1	Sensor 5.0V C			
A09	SEN_5V0_C2	Sensor 5.0V C			
A10	INJ_D4B_POS	Direct Injector 4B +			
A11	INJ_D1A_NEG	Direct Injector 1A -			
A12	INJ_D1B_NEG	Direct Injector 1B -			
A13	AV11	Analogue Voltage Input 11			
A14	DIG2	Digital Input 2			
A15	RS232_RX	RS232 Receive			
A16	SEN_5V0_C3	Sensor 5.0V C			
A17	INJ_D6A_POS	Direct Injector 6A +			
A18	SEN_0V_C1	Sensor 0V C			
A19	SEN_0V_C2	Sensor 0V C			
A20	SEN_0V_C3	Sensor 0V C			
A21	DIG1	Digital Input 1			
A22	LIN	LIN Bus			
A23	RS232_TX	RS232 Transmit			
A24	CAN2_HI	CAN Bus 2 High			
A25	INJ_D6B_POS	Direct Injector 6B +			
A26	INJ_D2A_NEG	Direct Injector 2A -			
A27	AV15	Analogue Voltage Input 15			
A28	AV16	Analogue Voltage Input 16			
A29	AV17	Analogue Voltage Input 17			
A30	DIG3	Digital Input 3			



Pin Number	Designation	Full Name	OE Pin	Function	Description
A31	CAN2_LO	CAN Bus 2 Low			
A32	INJ_D3A_POS	Direct Injector 3A +			
A33	INJ_D2B_NEG	Direct Injector 2B -			
A34	AV13	Analogue Voltage Input 13			
A35	AV12	Analogue Voltage Input 12			
A36	INJ_D6A_NEG	Direct Injector 6A -			
A37	DIG4	Digital Input 4			
A38	BAT_BAK	Battery Backup			
A39	CAN3_HI	CAN Bus 3 High			
A40	INJ_D3B_POS	Direct Injector 3B +			
A41	AV14	Analogue Voltage Input 14			
A42	INJ_D3A_NEG	Direct Injector 3A -			
A43	INJ_D4A_NEG	Direct Injector 4A -			
A44	INJ_D5B_NEG	Direct Injector 5B -			
A45	INJ_D6B_NEG	Direct Injector 6B -			
A46	CAN3_LO	CAN Bus 3 Low			
A47	INJ_D5A_POS	Direct Injector 5A +			
A48	INJ_D5B_POS	Direct Injector 5B +			
A49	INJ_D3B_NEG	Direct Injector 3B -			
A50	INJ_D4B_NEG	Direct Injector 4B -			
A51	INJ_D5A_NEG	Direct Injector 5A -			
A52	IGN_LS12	Low Side Ignition 12			
A53	IGN_LS9	Low Side Ignition 9			
A54	IGN_LS10	Low Side Ignition 10			
A55	IGN_LS11	Low Side Ignition 11			

### M182 Connector B — 26 way

Mating Connector A: Autosport 26 way Red - (Deutsch) AS6-16-26SN – MoTeC #65034

Pin Number	Designation	Full Name	OE Pin	Function	Description
B_A	OUT_HB1	Half Bridge Output 1			
B_B	OUT_HB2	Half Bridge Output 2			
B_C	OUT_HB3	Half Bridge Output 3			
B_D	OUT_HB4	Half Bridge Output 4			

Pin Number	Designation	Full Name	OE Pin	Function	Description
B_E	OUT_HB5	Half Bridge Output 5			
B_F	OUT_HB6	Half Bridge Output 6			
B_G	BAT_NEG1	Battery Negative			
B_H	BAT_POS1	Battery Positive			
B_J	BAT_POS2	Battery Positive			
B_K	BAT_POS3	Battery Positive			
B_L	BAT_POS4	Battery Positive			
B_M	OUT_HB10	Half Bridge Output 10			
B_N	OUT_HB9	Half Bridge Output 9			
B_P	OUT_HB8	Half Bridge Output 8			
B_R	OUT_HB7	Half Bridge Output 7			
B_S	INJ_LS4	Low Side Injector 4			
B_T	INJ_LS6	Low Side Injector 6			
B_U	INJ_LS1	Low Side Injector 1			
B_V	INJ_LS2	Low Side Injector 2			
B_W	BAT_NEG2	Battery Negative			
B_X	BAT_NEG3	Battery Negative			
B_Y	BAT_NEG4	Battery Negative			
B_Z	BAT_NEG5	Battery Negative			
B_a	INJ_LS5	Low Side Injector 5			
B_b	INJ_LS3	Low Side Injector 3			
B_c	BAT_NEG6	Battery Negative			

### M182 Connector C — 55 way

Mating Connector A: Autosport 55 way Red - (Deutsch) AS6-16-35SN – MoTeC #68090

Pin Number	Designation	Full Name	OE Pin	Function	Description
C01	IGN_LS4	Low Side Ignition 4			
C02	IGN_LS3	Low Side Ignition 3			
C03	IGN_LS8	Low Side Ignition 8			
C04	IGN_LS6	Low Side Ignition 6			
C05	IGN_LS5	Low Side Ignition 5			
C06	AV8	Analogue Voltage Input 8			
C07	AV10	Analogue Voltage Input 10			

Pin Number	Designation	Full Name	OE Pin	Function	Description
C08	IGN_LS2	Low Side Ignition 2			
C09	IGN_LS7	Low Side Ignition 7			
C10	UDIG8	Universal Digital Input 8			
C11	AV6	Analogue Voltage Input 6			
C12	AV7	Analogue Voltage Input 7			
C13	AV9	Analogue Voltage Input 9			
C14	SEN_OV_A1	Sensor 0V A			
C15	SEN_OV_A2	Sensor 0V A			
C16	IGN_LS1	Low Side Ignition 1			
C17	UDIG7	Universal Digital Input 7			
C18	UDIG1	Universal Digital Input 1			
C19	UDIG12	Universal Digital Input 12			
C20	UDIG11	Universal Digital Input 11			
C21	UDIG10	Universal Digital Input 10			
C22	UDIG9	Universal Digital Input 9			
C23	SEN_OV_B1	Sensor 0V B			
C24	CAN1_HI	CAN Bus 1 High			
C25	UDIG3	Universal Digital Input 3			
C26	ETH_RX-	Ethernet Receive-	Ethernet Orange		
C27	UDIG4	Universal Digital Input 4			
C28	AV4	Analogue Voltage Input 4			
C29	AV5	Analogue Voltage Input 5			
C30	SEN_OV_B2	Sensor 0V B			
C31	CAN1_LO	CAN Bus 1 Low			
C32	UDIG2	Universal Digital Input 2			
C33	ETH_RX+	Ethernet Receive+	Ethernet Orange/White		
C34	ETH_TX-	Ethernet Transmit-	Ethernet Green		
C35	AV3	Analogue Voltage Input 3			
C36	AV2	Analogue Voltage Input 2			
C37	AT1	Analogue Temperature Input 1		1k Pull up to SEN_5V_A	
C38	AT3	Analogue Temperature Input 3		1k Pull up to SEN_5V_B	
C39	AT2	Analogue Temperature Input 2		1k Pull up to SEN_5V_A	
C40	UDIG5	Universal Digital Input 5			

Pin Number	Designation	Full Name	OE Pin	Function	Description
C41	ETH_TX+	Ethernet Transmit+	Ethernet Green/White		
C42	AV1	Analogue Voltage Input 1			
C43	KNOCK3	Knock Input 3			
C44	KNOCK2	Knock Input 2			
C45	AT5	Analogue Temperature Input 5		1k Pull up to SEN_5V_C	
C46	AT4	Analogue Temperature Input 4		1k Pull up to SEN_5V_B	
C47	UDIG6	Universal Digital Input 6			
C48	SEN_5V0_A1	Sensor 5.0V A			
C49	KNOCK4	Knock Input 4			
C50	SEN_5V0_B1	Sensor 5.0V B			
C51	KNOCK1	Knock Input 1			
C52	AT6	Analogue Temperature Input 6		1k Pull up to SEN_5V_C	
C53	SEN_5V0_A2	Sensor 5.0V A			
C54	SEN_6V3	Sensor 6.3V			
C55	SEN_5V0_B2	Sensor 5.0V B			

## M190 Pinout

### M190 Connector A — 55 way

Mating Connector A: Autosport 55 way Yellow - (Deutsch) AS6-16-35SA – MoTeC #65031

Pin Number	Designation	Full Name	OE Pin	Function	Description
A01	INJ_LS3	Low Side Injector 3			
A02	INJ_LS2	Low Side Injector 2			
A03	INJ_LS1	Low Side Injector 1			
A04	INJ_LS12	Low Side Injector 12			
A05	INJ_LS4	Low Side Injector 4			
A06	LA_NB2	Lambda Narrow Input 2			
A07	LA_NB1	Lambda Narrow Input 1			
A08	SEN_5V0_C1	Sensor 5.0V C			
A09	SEN_5V0_C2	Sensor 5.0V C			
A10	INJ_LS8	Low Side Injector 8			
A11	INJ_PH1	Peak Hold Injector 1			
A12	INJ_PH2	Peak Hold Injector 2			
A13	AV11	Analogue Voltage Input 11			
A14	DIG2	Digital Input 2			
A15	RS232_RX	RS232 Receive			
A16	SEN_5V0_C3	Sensor 5.0V C			
A17	INJ_LS11	Low Side Injector 11			
A18	SEN_0V_C1	Sensor 0V C			
A19	SEN_0V_C2	Sensor 0V C			
A20	SEN_0V_C3	Sensor 0V C			
A21	DIG1	Digital Input 1			
A22	LIN	LIN Bus			
A23	RS232_TX	RS232 Transmit			
A24	CAN2_HI	CAN Bus 2 High			
A25	INJ_LS7	Low Side Injector 7			
A26	INJ_PH3	Peak Hold Injector 3			
A27	AV15	Analogue Voltage Input 15			
A28	AV16	Analogue Voltage Input 16			
A29	AV17	Analogue Voltage Input 17			
A30	DIG3	Digital Input 3			

Pin Number	Designation	Full Name	OE Pin	Function	Description
A31	CAN2_LO	CAN Bus 2 Low			
A32	INJ_LS10	Low Side Injector 10			
A33	INJ_PH4	Peak Hold Injector 4			
A34	AV13	Analogue Voltage Input 13			
A35	AV12	Analogue Voltage Input 12			
A36	INJ_PH7	Peak Hold Injector 7			
A37	DIG4	Digital Input 4			
A38	BAT_BAK	Battery Backup			
A39	CAN3_HI	CAN Bus 3 High			
A40	INJ_LS6	Low Side Injector 6			
A41	AV14	Analogue Voltage Input 14			
A42	INJ_PH9	Peak Hold Injector 9			
A43	INJ_PH10	Peak Hold Injector 10			
A44	INJ_PH6	Peak Hold Injector 6			
A45	INJ_PH5	Peak Hold Injector 5			
A46	CAN3_LO	CAN Bus 3 Low			
A47	INJ_LS9	Low Side Injector 9			
A48	INJ_LS5	Low Side Injector 5			
A49	INJ_PH11	Peak Hold Injector 11			
A50	INJ_PH12	Peak Hold Injector 12			
A51	INJ_PH8	Peak Hold Injector 8			
A52	IGN_LS12	Low Side Ignition 12			
A53	IGN_LS9	Low Side Ignition 9			
A54	IGN_LS10	Low Side Ignition 10			
A55	IGN_LS11	Low Side Ignition 11			

### M190 Connector B — 26 way

Mating Connector A: Autosport 26 way Red - (Deutsch) AS6-16-26SN – MoTeC #65034

Pin Number	Designation	Full Name	OE Pin	Function	Description
B_A	OUT_HB1	Half Bridge Output 1			
B_B	OUT_HB2	Half Bridge Output 2			
B_C	OUT_HB3	Half Bridge Output 3			
B_D	OUT_HB4	Half Bridge Output 4			

Pin Number	Designation	Full Name	OE Pin	Function	Description
B_E	OUT_HB5	Half Bridge Output 5			
B_F	OUT_HB6	Half Bridge Output 6			
B_G	BAT_NEG1	Battery Negative			
B_H	BAT_POS1	Battery Positive			
B_J	BAT_POS2	Battery Positive			
B_K	BAT_POS3	Battery Positive			
B_L	BAT_POS4	Battery Positive			
B_M	OUT_HB10	Half Bridge Output 10			
B_N	OUT_HB9	Half Bridge Output 9			
B_P	OUT_HB8	Half Bridge Output 8			
B_R	OUT_HB7	Half Bridge Output 7			
B_S	INJ_LS4	Low Side Injector 4			
B_T	INJ_LS6	Low Side Injector 6			
B_U	INJ_LS1	Low Side Injector 1			
B_V	INJ_LS2	Low Side Injector 2			
B_W	BAT_NEG2	Battery Negative			
B_X	BAT_NEG3	Battery Negative			
B_Y	BAT_NEG4	Battery Negative			
B_Z	BAT_NEG5	Battery Negative			
B_a	INJ_LS5	Low Side Injector 5			
B_b	INJ_LS3	Low Side Injector 3			
B_c	BAT_NEG6	Battery Negative			

### M190 Connector C — 55 way

Mating Connector A: Autosport 55 way Red - (Deutsch) AS6-16-35SN – MoTeC #68090

Pin Number	Designation	Full Name	OE Pin	Function	Description
C01	IGN_LS4	Low Side Ignition 4			
C02	IGN_LS3	Low Side Ignition 3			
C03	IGN_LS8	Low Side Ignition 8			
C04	IGN_LS6	Low Side Ignition 6			
C05	IGN_LS5	Low Side Ignition 5			
C06	AV8	Analogue Voltage Input 8			
C07	AV10	Analogue Voltage Input 10			

Pin Number	Designation	Full Name	OE Pin	Function	Description
C08	IGN_LS2	Low Side Ignition 2			
C09	IGN_LS7	Low Side Ignition 7			
C10	UDIG8	Universal Digital Input 8			
C11	AV6	Analogue Voltage Input 6			
C12	AV7	Analogue Voltage Input 7			
C13	AV9	Analogue Voltage Input 9			
C14	SEN_OV_A1	Sensor 0V A			
C15	SEN_OV_A2	Sensor 0V A			
C16	IGN_LS1	Low Side Ignition 1			
C17	UDIG7	Universal Digital Input 7			
C18	UDIG1	Universal Digital Input 1			
C19	UDIG12	Universal Digital Input 12			
C20	UDIG11	Universal Digital Input 11			
C21	UDIG10	Universal Digital Input 10			
C22	UDIG9	Universal Digital Input 9			
C23	SEN_OV_B1	Sensor 0V B			
C24	CAN1_HI	CAN Bus 1 High			
C25	UDIG3	Universal Digital Input 3			
C26	ETH_RX-	Ethernet Receive-	Ethernet Orange		
C27	UDIG4	Universal Digital Input 4			
C28	AV4	Analogue Voltage Input 4			
C29	AV5	Analogue Voltage Input 5			
C30	SEN_OV_B2	Sensor 0V B			
C31	CAN1_LO	CAN Bus 1 Low			
C32	UDIG2	Universal Digital Input 2			
C33	ETH_RX+	Ethernet Receive+	Ethernet Orange/White		
C34	ETH_TX-	Ethernet Transmit-	Ethernet Green		
C35	AV3	Analogue Voltage Input 3			
C36	AV2	Analogue Voltage Input 2			
C37	AT1	Analogue Temperature Input 1		1k Pull up to SEN_5V_A	
C38	AT3	Analogue Temperature Input 3		1k Pull up to SEN_5V_B	
C39	AT2	Analogue Temperature Input 2		1k Pull up to SEN_5V_A	
C40	UDIG5	Universal Digital Input 5			



Pin Number	Designation	Full Name	OE Pin	Function	Description
C41	ETH_TX+	Ethernet Transmit+	Ethernet Green/White		
C42	AV1	Analogue Voltage Input 1			
C43	KNOCK3	Knock Input 3			
C44	KNOCK2	Knock Input 2			
C45	AT5	Analogue Temperature Input 5		1k Pull up to SEN_5V_C	
C46	AT4	Analogue Temperature Input 4		1k Pull up to SEN_5V_B	
C47	UDIG6	Universal Digital Input 6			
C48	SEN_5V0_A1	Sensor 5.0V A			
C49	KNOCK4	Knock Input 4			
C50	SEN_5V0_B1	Sensor 5.0V B			
C51	KNOCK1	Knock Input 1			
C52	AT6	Analogue Temperature Input 6		1k Pull up to SEN_5V_C	
C53	SEN_5V0_A2	Sensor 5.0V A			
C54	SEN_6V3	Sensor 6.3V			
C55	SEN_5V0_B2	Sensor 5.0V B			

## Dimensions and Mounting

### M130

M130 - Small Case Tyco Connector

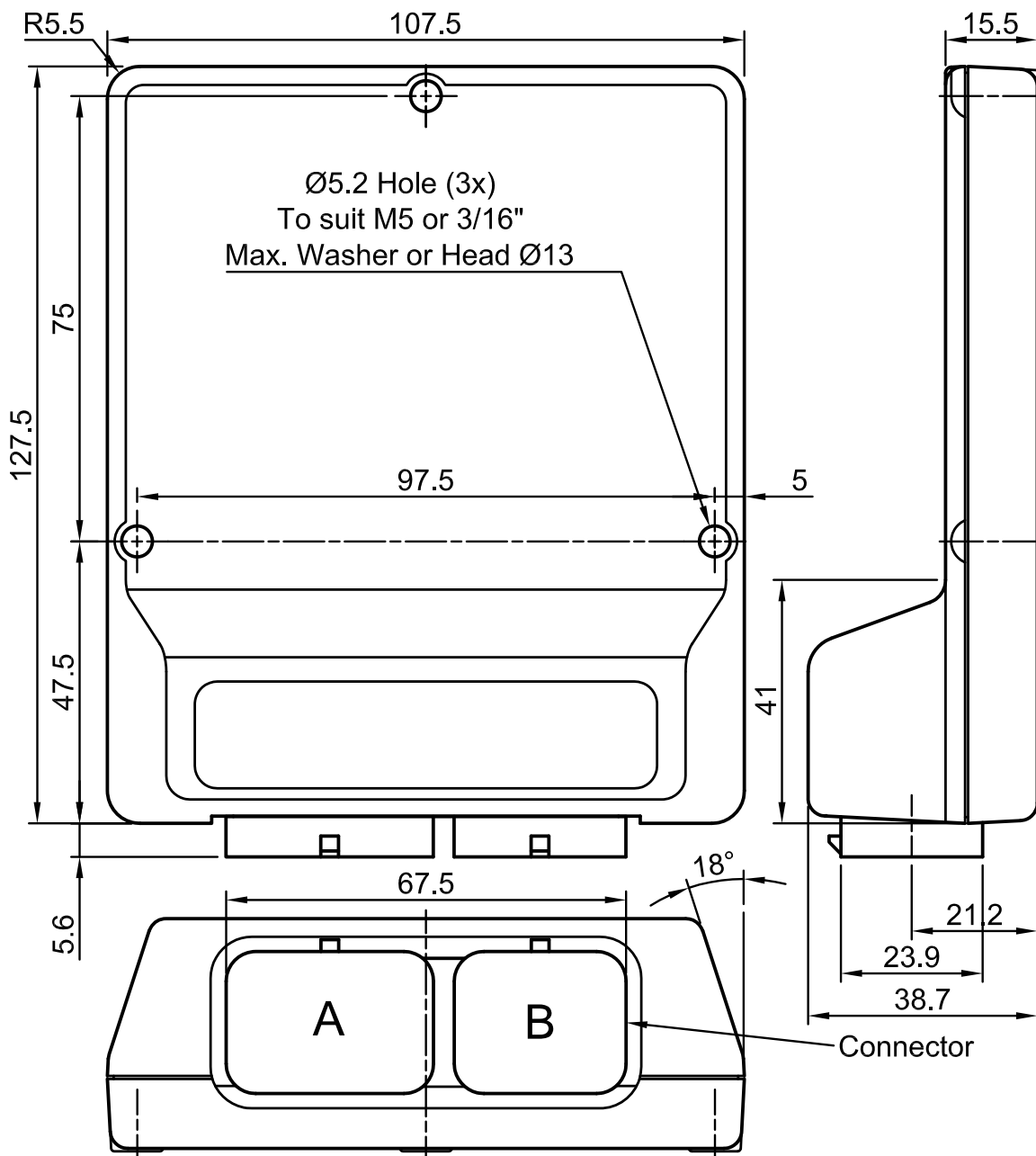

## M142 / M150

M142 / M150 - Large Case Tyco Connector

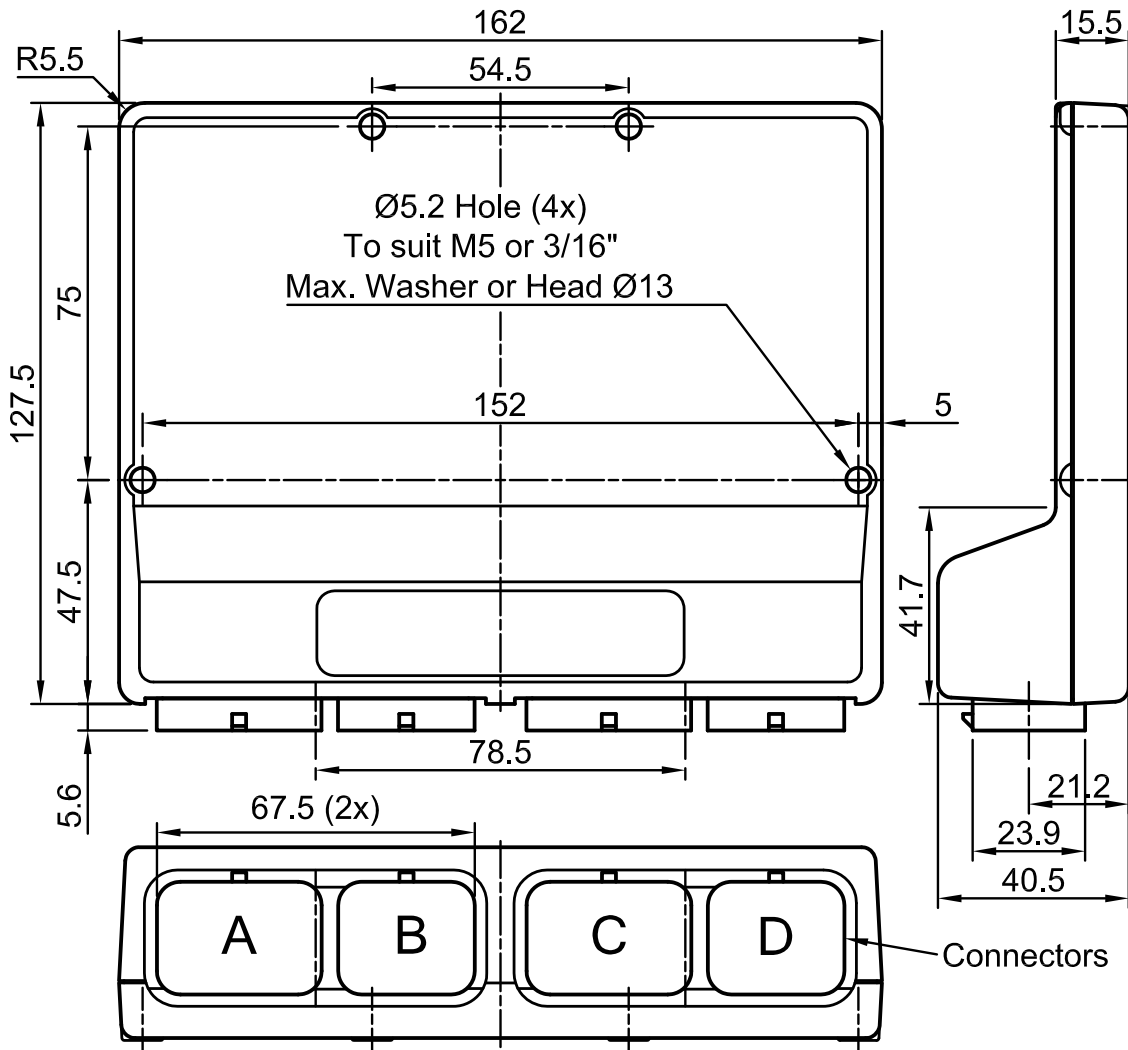

# M170

M170 - Small Case Autosport connector

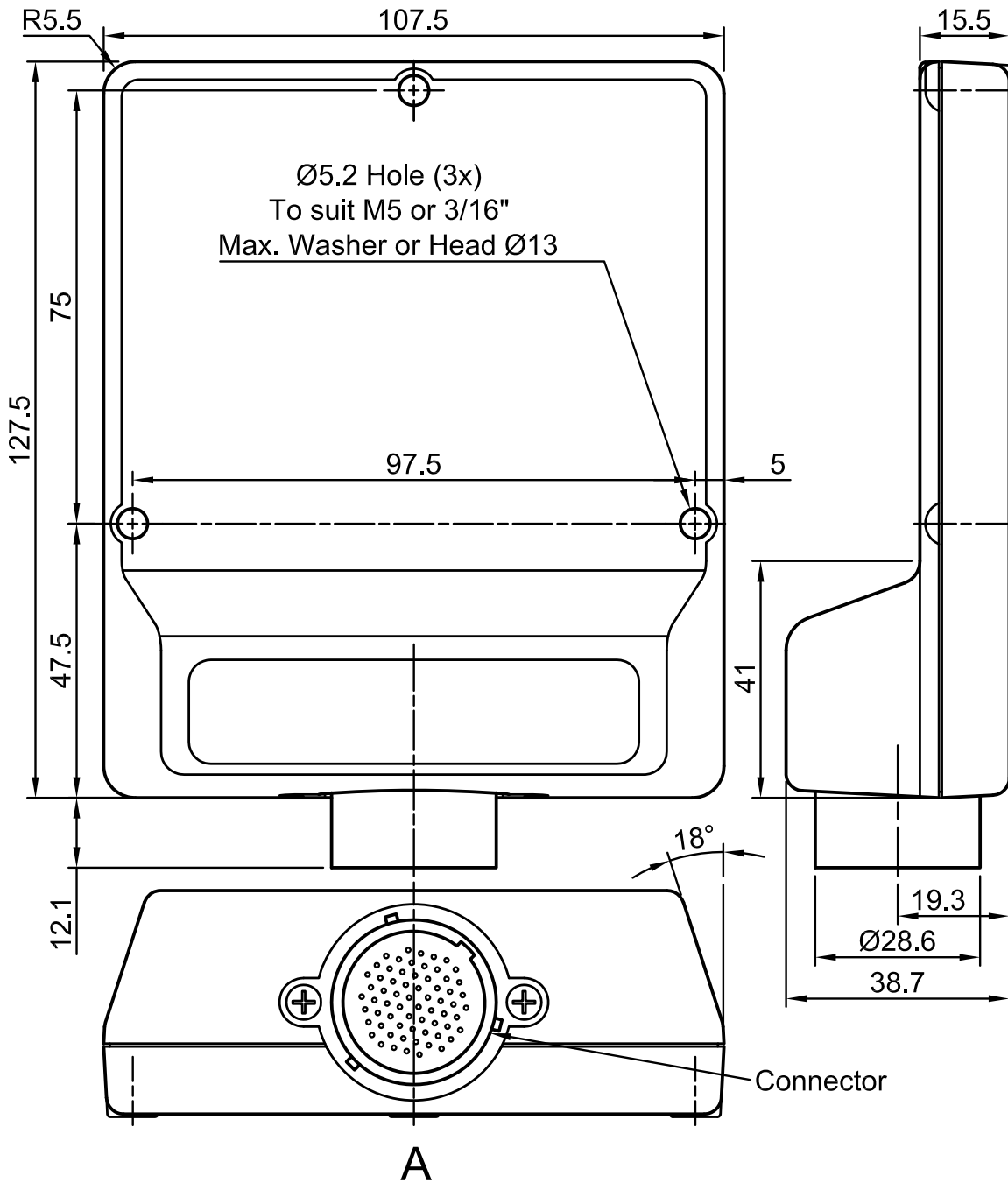

## M182 / M190

M182 / M190 - Large Case Autosport Connector

