



SDL3 - SPORT DASH LOGGER BACKLIT



The Sport Dash Logger Backlit (SDL3) comes standard as a combined display and powerful control device in one lightweight unit. With the addition of the Data Logging upgrade it becomes a fully programmable data logger with a 16 MB or 120 MB memory; and MoTeC's i2 data analysis software allows comprehensive analysis of logged data.

It offers the same construction and advanced technology as the top of the line ADL3, with a package of features tailored to more moderate system requirements. The SDL3 (backlit) performs calculations, acquiring data from other MoTeC devices, such as ECUs.

The layout of the backlit screen is fully configurable to display a multitude of data channels, warning alarms, lap times, fuel calculations, minimum corner speeds, maximum straight speeds and more.

Four auxiliary outputs are available to control external devices. With the use of an E888 expander, eight additional thermocouple outputs are available, making this versatile unit suitable for many applications.

► FEATURES

- All-in-one display, logger and controller
- Adjustable backlight
- Suitable for bikes, cars, marine and industrial applications

- Supports Wideband Lambda from MoTeC PLMs or LTCs
- Easily integrates with MoTeC CAN based products such as ECUs, expanders, lap timing devices and shift lights
- GPS Lap Timing
- Timers
- Engine Log

► ACCESSORIES

- Standard Ethernet cable
- Any one of the following Ethernet to Autosport connections:
 - 62202 – SDL3 loom
 - 61131 – Ethernet cable, unterminated, 2 metre
 - 61132 – Ethernet to Autosport pins cable, 1.8 metre

► UPGRADES

- Data Logging 16 MB: Allows recording of all input data to a 16 MB internal logging memory
- Memory 120 MB: Increases the internal logging memory to 120 MB (requires the Data Logging 16 MB upgrade).
- Pro Analysis: Provides access to advanced i2 Pro data analysis software.

► SPECIFICATIONS

Display

- Adjustable backlight (via software), using:
 - Channel value
 - Fixed percentage brightness
 - Combination channel value and percentage brightness
- 70 segment bar graph
- 13 digit alphanumeric text bar
- 48 user-defined, scrollable message lines with programmable overrides
- 3 programmable 'pages' for Practice, Warm-Up and Race

Logging

- Optional 16 MB or 120 MB logging memory
- Logging rates up to 500 samples per second
- Fast Ethernet download

Inputs

- 8 x Analogue voltage inputs, some are high resolution inputs
- 4 x Analogue temperature inputs
- 2 x Digital inputs
- 4 x Speed inputs with voltage measuring capability
- Compatible with up to two E888 expanders (8 Thermocouples only)

Outputs

- 4 x PWM, switched or digital outputs

Internal Sensors

- 3-axis accelerometer, detection range: +/- 5G
- Dash temperature sensor
- Sensor supply voltage
- Battery voltage

Communications

- 2 x CAN with individually programmable CAN bus speeds
- 1 x RS232

Physical

- Dimensions 180 x 91 x 18 mm excluding connector
- Weight 385 g
- 1 x 37 pin Autosport connector

► SOFTWARE

Windows-based software designed for setup and management of the display and data logging system, that provides:

- Configuration of the inputs, outputs, LEDs, display, data logging and calculations
- Offline generation of a configuration file that can then be sent to the device.
- Channel monitoring
- Firmware updating and extensive help screens

► DIMENSIONS AND MOUNTING

Dimensions are in mm. Ensure product is not stressed when mounted.

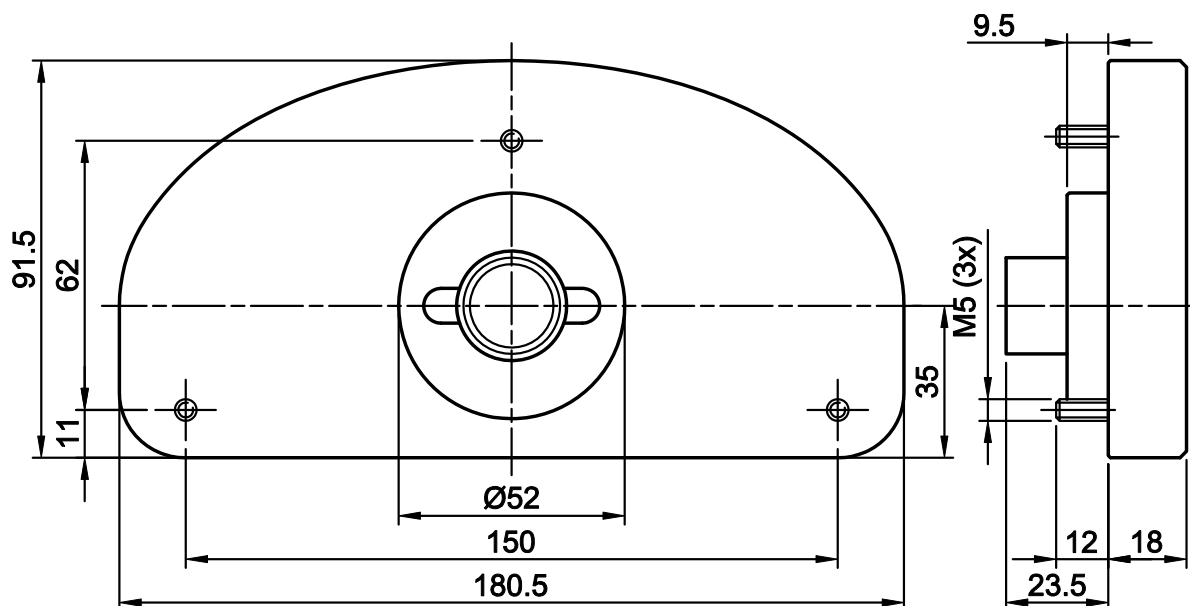

▶ **ETHERNET WIRING**

Ethernet Connector		MoTeC Loom Colour	SDL3	
Pin	Function		Pin	Function
1	ethernet TX +	orange/white	24	ethernet RX +
2	ethernet TX -	orange	9	ethernet RX -
3	ethernet RX +	green/white	25	ethernet TX +
6	ethernet RX -	green	10	ethernet TX -

⇒ The wiring specified is the preferred cross-over configuration. However, the wiring can also be configured as straight-through. Cat 5 Ethernet cable must be used.

Pin Numbering

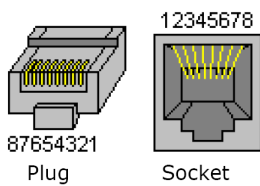

▶ **ECU WIRING**

When using an M4, M48 or M8 ECU, the SDL3 should be connected via RS232. For some ECUs, a PCI cable may also be required.

The Display Logger should be connected via the CAN bus when using a 'hundred series' ECU (M400/M600/M800/M880) or M84, and any number of other CAN devices. See the following example.

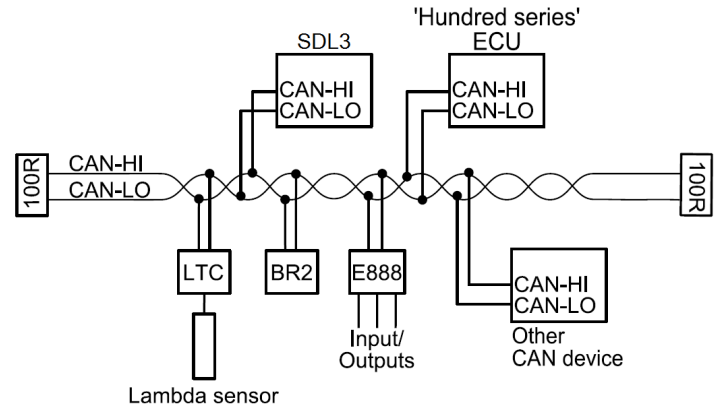

Detailed wiring information is available in the user manual at www.motec.com/downloads.

▶ **PINOUT**

Pin	Name	Function
1	AV5	Analogue Voltage Input 5
2	AV6	Analogue Voltage Input 6
3	BAT+	Battery Positive
4	BAT-	Battery Negative
5	AUX1	Auxiliary Output 1
6	AUX2	Auxiliary Output 2
7	AUX3	Auxiliary Output 3
8	AUX4	Auxiliary Output 4
9	E-RX-	Ethernet Receive -
10	E-TX-	Ethernet Transmit -
11	SPD3	Speed Input 3
12	SPD4	Speed Input 4
13	8V	Sensor 8 V
14	5V	Sensor 5 V
15	AV1	Analogue Voltage Input 1
16	AV2	Analogue Voltage Input 2
17	AV3	Analogue Voltage Input 3
18	AV4	Analogue Voltage Input 4
19	AV7	Analogue Voltage Input 7
20	AV8	Analogue Voltage Input 8

Pin	Name	Function
21	AT1	Analogue Temp Input 1
22	AT2	Analogue Temp Input 2
23	SPD1	Speed Input 1
24	E-RX+	Ethernet Receive +
25	E-TX+	Ethernet Transmit +
26	SPD2	Speed Input 2
27	DIG1	Digital Input 1
28	DIG2	Digital Input 2
29	CAN1L	CAN 1 Low
30	CAN1H	CAN 1 High
31	AT3	Analogue Temp Input 3
32	AT4	Analogue Temp Input 4
33	TX	RS232 Output
34	RX	RS232 Input
35	CAN0L	CAN 0 Low
36	CAN0H	CAN 0 High
37	0V	Sensor 0 V