



# LAMBDA TO CAN - DUAL (LSU VERSION) LONG LOOM



**MoTeC's LTC D (Lambda To CAN) is a dual sensor version LTC. It monitors, controls and diagnoses two Bosch LSU 4.9 Lambda sensors, and transmits Lambda readings on a CAN bus. When using dual LTCs or a mix of singular and dual LTCs, up to 32 Lambda sensors can be configured on a single CAN bus for simultaneously monitoring.**

## ► FEATURES

- Provides accurate Lambda measurement even when exhaust gas temperature is changing rapidly (heating or cooling).
- Calibrated by the user for a particular sensor using either the initial sensor factory calibration, the free air calibration, or (for NTK sensors only) the referenced gas calibration.
- Pre-configured to suit a single unit installation. If necessary, the configuration can be adjusted; see the Configuration section for more details.
- Version 2 units (marked with a 2 under the barcode) are able to transmit extended Lambda values (Rich Lambda).

## ► COMPATIBILITY

### MoTeC ECU Models

- M1 Series, M84, M400, M600, M800, M880

### MoTeC Display/Logger Models

- All C Series Display Loggers, ACL, CDL3 (and discontinued models: SDL, SDL3, ADL, ADL2, ADL3)

## ► PC COMMUNICATIONS

A MoTeC gateway device is required to communicate with the LTC on CAN. Such devices include:

- M1 Series ECUs
- All C Series Display Loggers, ACL, ADL3, SDL3, CDL3
- UTC (USB to CAN) #61059

## ► SPECIFICATIONS

### Inputs/Outputs

- 2 x Bosch LSU 4.9 Lambda sensors
- Power supply voltage for each sensor: 11 V - 16 V
- Power supply current for each sensor: 110 mA typical plus the sensor heater current. Heater current is typically 0.5 A - 1 A and up to 2 A on startup.

### Communications

- 1 x CAN - using LTC Manager, configurable to: 125 Kbps, 250 Kbps, 500 Kbps or 1 Mbps

### Physical

- Dimensions: 38 x 26 x 23.5 mm, excluding wiring looms and connectors
- Weight: 100 g
- 1 x 4 pin male DTM connector (power/CAN)
- 2 x mating connectors for Bosch LSU 4.9 sensor
- Maximum ambient temperature: 100 °C

## ► SOFTWARE

For multiple installations, LTC Manager software allows all units to be simultaneously managed and diagnosed.

The software is used to:

- Configure and calibrate all units on the CAN bus
- Display readings and diagnostics
- Configure CAN transmission addresses
- Control free air sensor calibration
- Update unit firmware.

## ► CONFIGURATION

MoTeC LTCs come pre-configured to suit a single LTC unit installation. By default, the initial factory sensor calibration is used and the following CAN addresses:

Sensor 1 — 460

Sensor 2 — 461

It is only necessary to use LTC Manager if installing multiple LTC units, or if changes to the default settings are required.

► DIMENSIONS AND MOUNTING

All dimensions in mm.

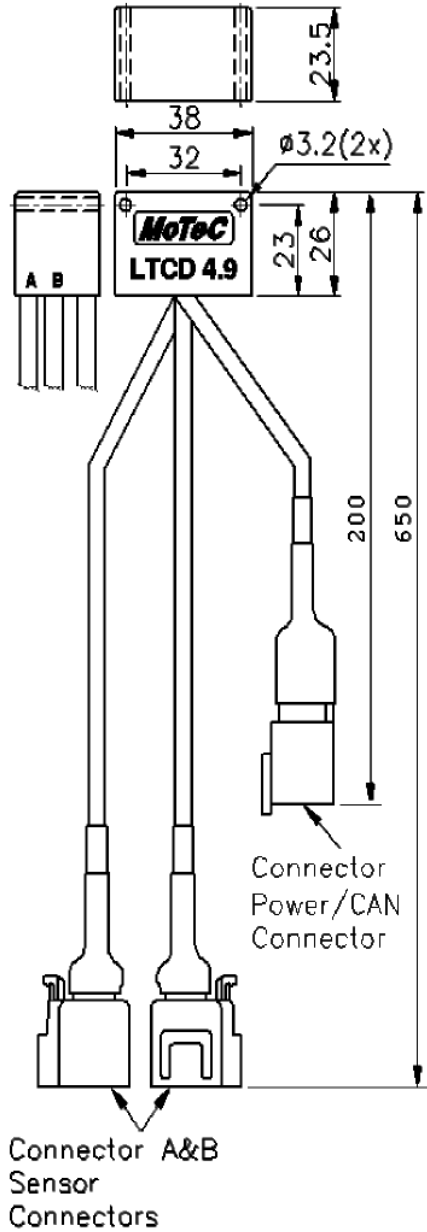

► CONNECTOR PINOUTS

**Connector A (and B for Dual version)**

Bosch LSU 4.9 sensor connector

Mating connector: supplied on sensor

Pin	Wire Colour	Description
1	Red	Ip
2	Yellow	Sensor 0 V
3	White	Heater -
4	Grey	Heater +
5	Green	Ipr
6	Black	Vs

**Power/CAN Connector**

DTM 4 Pin (M) (#68055)

Mating connector: DTM 4 Pin (F) #68054

Pin	Wire Colour	Description
1	Black	Battery -
2	Green	CAN Lo
3	White	CAN Hi
4	Red	Battery +

► WIRING

To power the LTC, connect to either the ignition switch for fast sensor start up or the fuel pump relay to prevent accidental battery drainage.

*Wiring example*

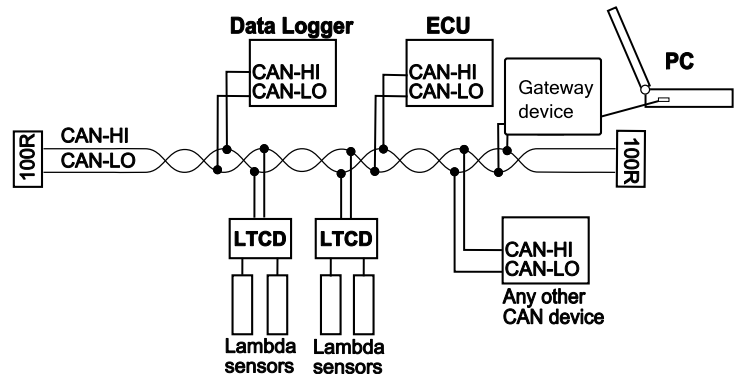

For information on wiring a CAN bus with several LTCs and any number of other CAN devices (as per the example), refer to the relevant device manual.